

SHARK SH 910

TECHNICAL DATA

SHREDDER

- Crusher inlet opening	mm.	1000x950
- Fixed grinders adjustement		Hydraulic

HOPPER

- Length	mm.	3000
- Width	mm.	2000
- Hopper capacity	m ³	2,2
- Loading height	mm	2620

EXTRACTING BELT

- Length	mm.	5300
- Width	mm.	800
- Pile height	mm.	1800

KOHLER TURBO ENGINE

- Power	kW/Hp	95\127
- Consumption at	L/h	18
- Cylinder	N°	4
- Cooling		water

*The shredder production performance depends by the type of material and by the size of the material needed after the shredding process.

CRAWLED TRACK WITH PADS

- Length	mm.	2750
- Width	mm.	400
- Speed	No.	1°0,7 km\h 2° 2,2 km\h

*PERFORMANCE

- Production	T/h	120
- Standard weight	Kg.	14.000

STANDARD MACHINE

- Remote control for all the movements
- Ladder to inspect the crusher
- Protection for inspection footboard

ACCESSORIES

- Magnetic belt
- Dust dumping system

DIMENSION

	Work	Trasport
- Length	7000	7000
- Width	2250	2250
- Height	2620	2620

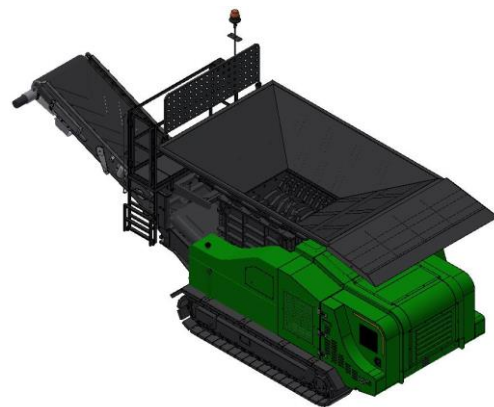
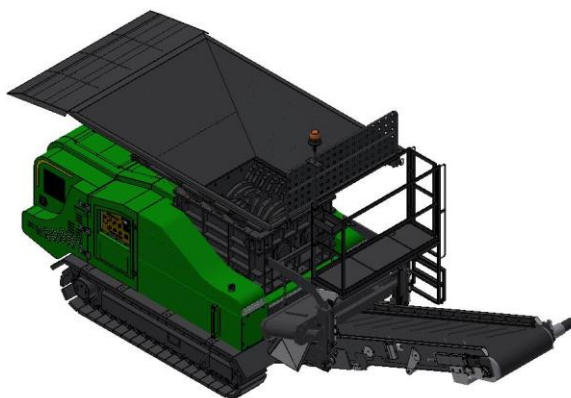

The technical data and specification hereby supplied are merely indicatives. Komplet reserves the right to modify them without notice

Dealer:



www.komplet.it info@komplet.it

+39 071 66 09 823 +39 071 66 11 069

