

RM  
RUBBLE MASTER



RM60

COMPACT RECYCLING FOR WINNERS

**RUBBLE MASTER**<sup>®</sup>  
COMPACT RECYCLER



Easy handling: fed with small construction loaders (loading edge 190 cm), remote control optional



Indispensable: release system to remove blockages, plus reliable magnetic separator



Efficient: automatic 2-step conveying and diesel / electric drive (9 to 12 l)

RUBBLE MASTER Compact Recyclers are the compact class for mobile processing: they are versatile in use, powerful and stable in value. They produce high-quality cubic value grain from construction debris and natural rock on-site and cost effectively. Thanks to their compact dimensions and low weight, they can be transported without any special permits. Proven technology, individual advice and the RM Lifetime Support programme enable the RUBBLE MASTER user to offer affordable, mobile recycling and establish a profitable line of business with exceptional quality. Because we are only satisfied when our customers are successful!

## LUCRATIVE NICHE



Appreciated by residents: thanks to series dust suppression and noise reducing cover





# THROUGH QUALITY AND MOBILITY

## RM60 – THE FLEXIBLE PROBLEM-SOLVER

The RM60 is the most compact RM crusher and perfect for newcomers to recycling. Instead of the burden of ever increasing costs, mobile recycling that uses existing equipment and personnel can generate additional profit, eliminating transport, dumping and procurement costs at the same time. The RM60 is moved from site to site using a hook lift lorry and ready for operation in a short space of time.

The impact crusher is easy to operate and all service jobs can be carried out from ground level. With high-performance components such as pre-screens and final screens, you can create a complete recycling centre. The building contractor becomes a service provider for companies and communities, creating clear, cost-efficient recycling loops. RUBBLE MASTER partners offer advice on optimum settings and site logistics on a case-to-case basis.



Less wear through pre-screening: the robust VS60 – also available with side conveyor belt – separates fines from the feed material



Profitable niches: recycled production waste can be separated in the container-mobile CS2500 and reused to save costs



Success factor quality and pure sorting: up to 80 t/h cubic value grain from building debris, asphalt, concrete and in landscape design

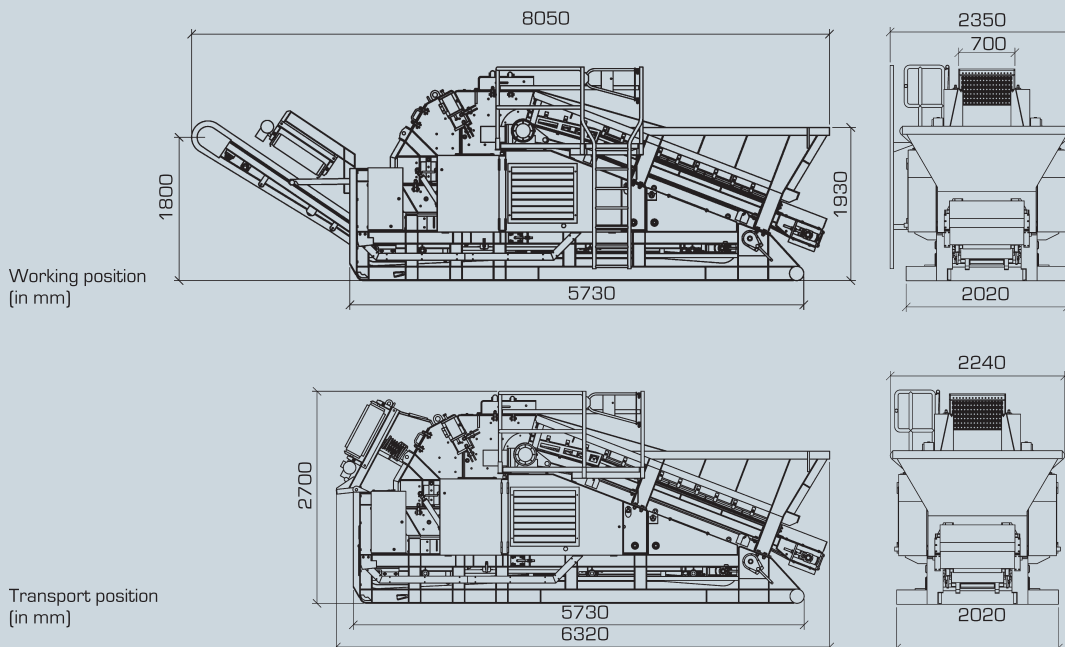

**RM60** - hook-lift mobile impact crusher

Throughput	Up to 80 t/h, depending on material
Feed size	Diameter max. 500 mm
Inlet opening	640 x 550 mm
Crusher unit	HMH impact crusher with 2 or 4 hammers Kinematics mechanically adjustable for primary or secondary crushing
Operation	Straightforward handling with remote control (optional)
Feed unit	Feed hopper 1 m <sup>3</sup> The hopper is a solid, reinforced steel structure Loading height 1,930 mm, loading width 2,500 mm Conveyor trough width 640mm Feed Control System (1st generation automation) for automatic conveying in line with crusher load
Discharge belt	Folding conveyor 650 mm wide, cranked mechanically into transport position Discharge height 1,800 mm
Drive unit	Deutz diesel engine, 4 cylinder 67 kW at 2,000 rpm TIER 2 / COMII; from 2008 TIER 3 / COM III approved 3-phase synchronous generator 19 kVA 400 V 230 V and 400 V outlets for external drives up to 6 kW
Magnetic separator	Extra strong magnet, belt width 650 mm
Emission protection	RUBBLE MASTER enviro concept: Dust suppression using water spray inside crusher and at outlet
Transport system	Hook unit on truck
Weight	12,000 kg
Options	Release System to remove blockages inside crusher Remote control Service platform Filling pump Crusher hammer changing system Hydraulic legs

Specifications subject to change in line with technical developments.

[www.rubblemaster.com](http://www.rubblemaster.com)

**RUBBLE MASTER®**  
COMPACT RECYCLER

**HMH**

RUBBLE MASTER HMH GmbH  
Im Südpark 196 - AT 4030 Linz - Austria  
T +43 (0) 732 . 73 71 17-360  
F +43 (0) 732 . 73 71 17-101  
sales@rubblemaster.com